

Robust precision.

MAGRES EAM – Magnetic absolute encoders



Proven robustness. Highest precision up to $\pm 0.15^\circ$.

MAGRES absolute encoders are well-proven under harsh conditions all over the world. The new generation combines this proven robustness with highest precision for efficient process control and best performance in every environment.

In their new *MAGRES EAM* generation, Baumer consistently pursued further enhancement of the proven design for even more durability and extended service life in demanding environments. Another focus was on high-precision magnetic sensing for higher measuring accuracy to boost your application efficiency.

Thanks to ISO 13849 – compliant firmware, it is possible to integrate the encoders into safety functions up to PLd. Final system classification and PLd approval (hardware & software) must only be carried out by the corresponding supervisory authorities. Reduced to the essential and in a modular design, you are offered extremely high versatility with an excellent price-performance ratio.

MAGRES EAM – durable, efficient, reliable

Technical highlights

- Wear-free magnetic sensing
- Angular accuracy up to $\pm 0.15^\circ$
- Wide temperature range $-40...+85^\circ\text{C}$
- High shock and vibration resistance up to 500 g / 30 g
- Protection class up to IP 67
- Robust *ShaftLock* flange design
- ISO 13849 compliant firmware
- Redundant versions
- Wide range of interfaces (SSI, Analog, fieldbus, real-time Ethernet)
- Additional incremental signals up to 4096 pulses

Your benefits at a glance

- Reliable operation in harsh environments
- Precise positioning by high measuring accuracy
- High flexibility thanks to broad portfolio
- Excellent price-performance ratio



SSI
HTL / TTL

CANopen
SAE J1939



0...10 V
0.5...4.5 V
4...20 mA



Flexible and ready for the future. For your ideas of tomorrow.

MAGRES EAM580 real-time Ethernet suits every application in industrial environments.

PROFINET – for maximum system uptime

- Increased system uptime thanks to Media Redundancy Protocol (MRP). In the event of line or switch failure in ring topologies, the system will continue operation free from error.
- No pre-parameterization in device exchange required thanks to Link Layer Discovery Protocol (LLDP): The EAM580 utilizes neighborhood detection for time-saving replacement.
- Supporting the operating modes Realtime (RT) and Isochronous Realtime (IRT) to match the application-specific requirements on real-time and synchronicity.

EtherCAT – for extremely fast & precise applications

- Easy and intuitive commissioning: Convenient device address allocation and firmware update via controller.
- Minimum cycle time (62.5 μ s) for high-precision, synchronous motion control.
- Supporting the operating modes Free Run, Synchronous Mode and Distributed Clocks for optimum EAM580 adaptation to the application requirements.

EtherNet/IP – for universal data access

- In the event of interrupted plant network (ring topology), encoder data transmission to the controller is secured by Device Level Ring (DLR).
- Access to encoder and process data via office network and control via integrated web server.

Industry 4.0 and IoT ready

- Absolute encoders of the EAM580 series with PROFINET support OPC UA.
- This open, platform-independent communication standard is widely used and easily adaptable to future requirements.

EtherCAT®

EtherNet/IP™

PROFINET®

OPC UA





Robust and precise. The perfect combination.

Precise also in demanding applications

Innovative high-precision magnetic sensing allows for use in applications where so far optical encoders were required. The high measuring accuracy of $\pm 0.15^\circ$ now provides you with the benefits of durable magnetic sensing technology in almost any application.

Furthermore, this high precision will simplify application design, especially in terms of redundant use of encoders.

Encoders of the *MAGRES EAM* series excel by extreme measuring stability regarding temperature, speed and changes in the rotation direction. These capabilities make them meet every requirement even in demanding applications.

Magnetic shield integrated

The steel housing offers 10 times better protection from external magnetic fields compared to other materials, e.g. aluminum.

For use in corrosive environments up to category CX (C5-M)

Maximum protection and durability by powder-coated housing and flange made of corrosion-resistant aluminum alloy.

Excellent price performance ratio

Cost-efficient design thanks to limited number of components and high modularity.

Resistant to shocks up to 500 g and vibration up to 30 g

Ultimate resistance by omission of any parts prone to vibration and breakage.

Measuring accuracy up to $\pm 0.15^\circ$

Magnetic precision sensing will enhance efficiency in your application, even in demanding environments.



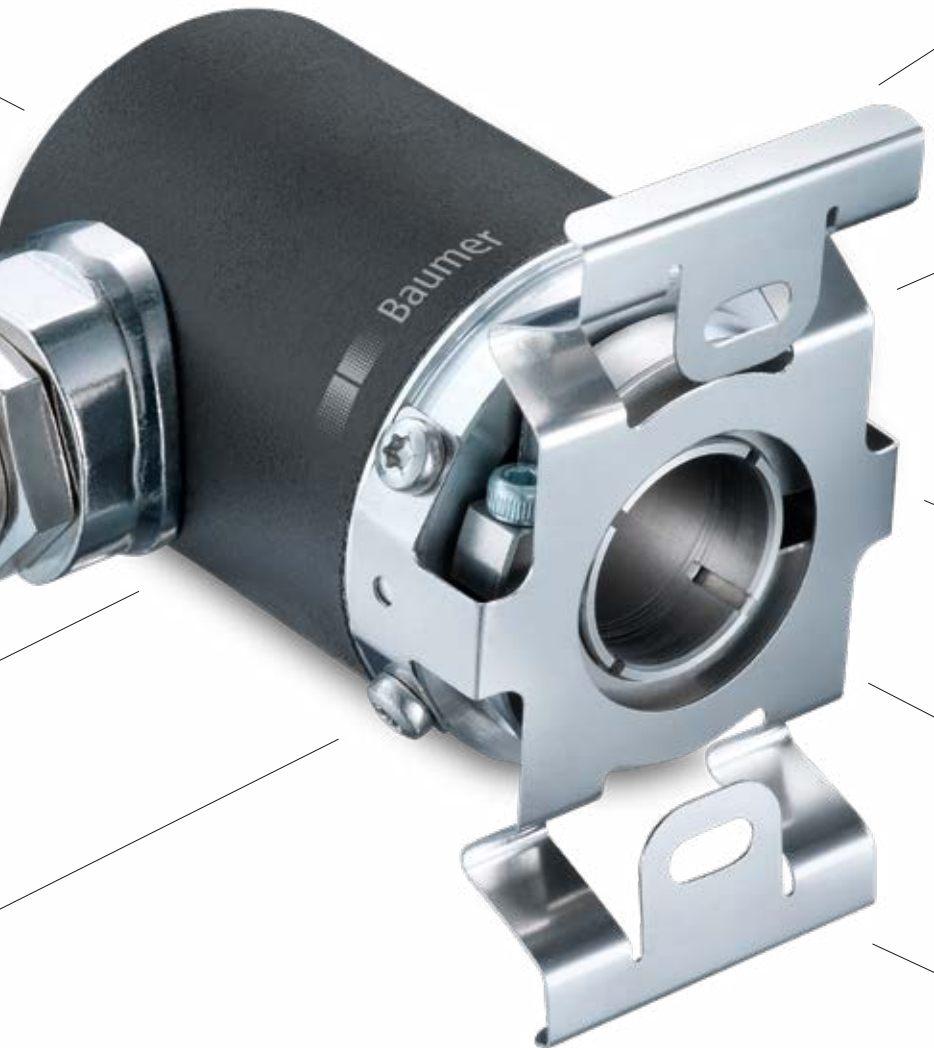

Operating temperature $-40...+85\text{ }^{\circ}\text{C}$
Magnetic precision sensing withstanding temperature fluctuations and condensation.

Protection class IP 67: Durable also in outdoor applications
Maximum protection by radial shaft seal and innovative connector/PG design.

Small encoder, big hollow shaft up to $\varnothing 15\text{ mm}$.
High flexibility even in compact design of 36 mm.

Flange in robust *ShaftLock* design
The sophisticated design prevents axial shaft penetration which makes the encoder largely immune against incorrect installation.

Shaft load radial 80 N / axial 40 N
Both the 58 and 36 mm design features robust, large-sized and widely spaced ball-bearings.



Highest reliability. ISO 13849 compliant firmware.

Do you have experience with the application of standard components with embedded software in safety functions? With *MAGRES EAM* Baumer offers an economic encoder which is easy to integrate.

Application Note for efficient integration

The *MAGRES EAM* encoder software was developed in accordance to ISO 13849 standard and therefore are ideal for integration in overall certified systems up to PLd. The application note provides you with all information necessary for efficient safety assessment.

Our sales and customer support team will gladly be of help should you have any questions about the product.

EAM580R & EAM360R: robust²

Uncompromised durability for mobile automation and demanding outdoor conditions. The R-series EAM580R and EAM360R

exhibits further design features for increased requirements, which drive the product robustness to the top.

- High EMC robustness with E1 compliant design
- Reliable longterm use in outdoor environments with protection class IP 67 and CX (C5-M) corrosion protection
- Robust wire cross section of 0.5 mm² for cable versions with optional mobile connectors (e.g. DEUTSCH)

EAM Multiturn Kit with air gap up to 2 mm

The bearingless Kit versions are practically wear-free and therefore extremely durable. The hermetically sealed design perfectly protects them from any kind of pollution. The big axial air gap of 2 mm ensures easy integration.



Your individual requirements. Our broad portfolio.

The modular design is key for a versatile and economic product family.

The *MAGRES EAM580* series provides extremely space-saving variants for limited installation space, whereas *MAGRES EAM360* excels by compact diameters. Both designs offer highest flexibility by every common flange type being available both with shaft and hollow shaft from 6...15 mm diameter and even as bearingless kit version.

Thanks to the modular product architecture, the 36 mm design integrates the same large-sized ball bearings used in the 58 mm design, which results in particularly high robustness.

You need a very special configuration, for example individually modified in mechanical design? With a customized product adapted to your application you will always get the optimum solution in terms of technology.

Our experts gladly provide you with a corresponding quotation. Contact us:

www.baumer.com/worldwide

Designs and connections

Size 58 mm



Clamping flange



3 x M12



Synchro flange



M23



Blind hollow shaft



Cable



Kit



M12

Size 36 mm



Synchro flange



Blind hollow shaft



Kit



M12



Cable

Only versions with powder coated housing displayed. This is available as standard for EAM580R and EAM360R, otherwise on request.

Product overview *MAGRES* EAM580 & EAM360



	EAM580	EAM580R	EAM360	EAM360R
Sensing method	Magnetic			
Size	ø58 mm		ø36 mm	
Voltage supply	4.5 ... 30 VDC (SSI) 8 ... 30 VDC / 14 ... 30 VDC (analog - type specific) 10 ... 30 VDC (CANopen®, SAE J1939, PROFINET, EtherCAT, EtherNet/IP)			
Function	Singleturn / Multiturn			
Angular accuracy	Up to 0.15°			
Steps per turn	Up to 14 bits			
Number of turns	Up to 18 bits			
Interface	SSI, CANopen®, PROFINET, EtherCAT, EtherNet/IP (SSI, CANopen® optional with incremental signals)	CANopen®, CANopen® redundant, SAE J1939, Analog (0.5 ... 4.5 VDC, 0 ... 10 VDC, 4 ... 20 mA)	SSI, CANopen® (SSI, CANopen® optional with incremental signals)	CANopen®, SAE J1939, Analog (0.5 ... 4.5 VDC, 0 ... 10 VDC, 4 ... 20 mA)
Shaft type	Solid shaft, hollow shaft or kit			
Shaft diameter	ø10, ø12, ø14 and ø15 mm (hollow shaft) ø10 mm (clamping flange) ø6 mm (synchro flange) ø6, ø8 and ø12 mm (kit)		ø10, ø12, ø14 and ø15 mm (hollow shaft) ø10 mm (synchro flange) ø6, ø8 and ø12 mm (kit)	
Shaft load	40 N axial, 80 N radial			
Operating temperature	-40 ... +85 °C			
Shock resistant DIN EN 60068-2-27	Up to 500 g, 1 ms			
Vibration resistant DIN EN 60086-2-6	Up to 30 g, 10 ... 2000 Hz			
Protection DIN EN 60529	IP 65, IP 67	IP 67	IP 65, IP 67	IP 67
Connection	Flange connector M12/M23 Cable 0.14 mm ²	Flange connector M12 Cable 0.5 mm ²	Flange connector M12 Cable 0.14 mm ²	Flange connector M12 Cable 0.5 mm ²

Further information on *MAGRES* EAM580 and EAM360 encoder series at:
www.baumer.com

Find your local partners at: www.baumer.com/worldwide



Baumer Group
 International Sales
 P.O. Box
 Hummelstrasse 17
 CH-8501 Frauenfeld
 Phone +41 52 728 1122
 Fax +41 52 728 1144
sales.ch@baumer.com